



# Double Union Ball Valve

**2013U**  
2000 WOG  
¼" - 2"

**Blowout Proof  
Stem**

**Stainless Steel Latch  
Lock Handle**

**RPTFE Seats**

**Adjustable PTFE  
Stem Packing**

**Full Bore Solid  
316 Stainless  
Steel Ball**

**Investment Cast  
CF8M Body**

**NPT, Union  
Connections**

- Heavy Duty Construction
- PTFE Packing & Seals

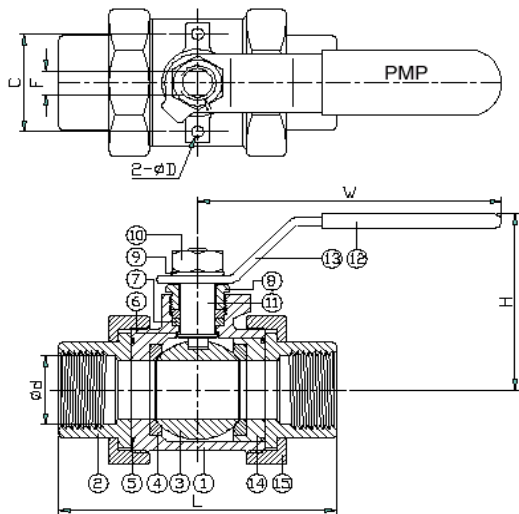
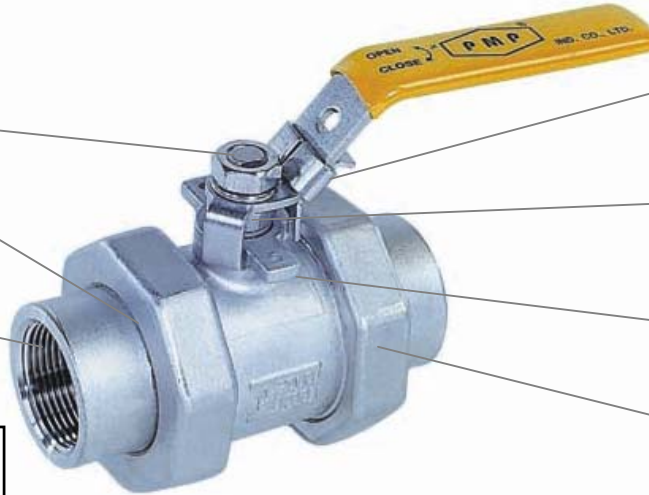

NO.	PART NAME	SPECIFICATION
1	BODY	ASTM A351-CF8M
2	CAP	ASTM A351-CF8M
3	BALL	ASTM A351-CF8M
4	SEATS	RPTFE
5	BODY SEAL	PTFE
6	THRUST WASHER	PTFE
7	PACKING	PTFE
8	GLAND NUT	AISI 304
9	STEM WASHER	AISI 304
10	HANDLE NUT	AISI 304
11	STEM	ASTM A276-316
12	HANDLE SLEEVE	PVC
13	HANDLE	AISI 304
14	RETAINER	ASTM A351-CF8M
15	CAP NUT	ASTM A351-CF8M

SIZE		1/4"	3/8"	1/2"	3/4"	1"	1-1/4"	1-1/2"	2"
d	in	0.35	0.50	0.50	0.79	1.00	1.25	1.50	2.00
	mm	10	12	15	20	25	32	40	50
L	in	3.54	3.54	3.94	4.09	4.80	5.04	5.59	6.50
	mm	90	90	100	104	122	128	142	165
H	in	2.09	2.09	2.32	2.44	2.87	3.07	3.54	3.86
	mm	53	53	59	62	73	78	90	98
W	in	3.94	3.94	4.72	4.72	5.71	5.71	6.89	6.89
	mm	100	100	120	120	145	145	175	175
C	in	1.13	1.13	1.42	1.42	1.65	1.65	1.97	1.97
	mm	28.6	28.6	36	36	42	42	50	50
D		M 4	M 4	M 5	M 5	M 5	M 5	M 6	M 6
F	in	0.20	0.20	0.24	0.24	0.31	0.31	0.39	0.39
	mm	5	5	6	6	8	8	10	10

PMP Precision Valve Company Ltd. Is a progressive supplier of current products. The features, materials of construction and dimensional data as detailed in this bulletin are intended for your reference only, and should not be relied upon unless confirmed in writing by PMP Precision Valve Co. Ltd.. Certified dimensional drawings are available upon order receipt.