



Globe Valve

2028

600 WOG

1/2" - 2"

Non-Rising Stem

Threaded ends conform to ASME B1.20.1 (NPT)

- Investment cast body
- Max working pressure 600psi CWP
- Option:** PTFE Seat



Screwed Bonnet

Metal X Metal Seat

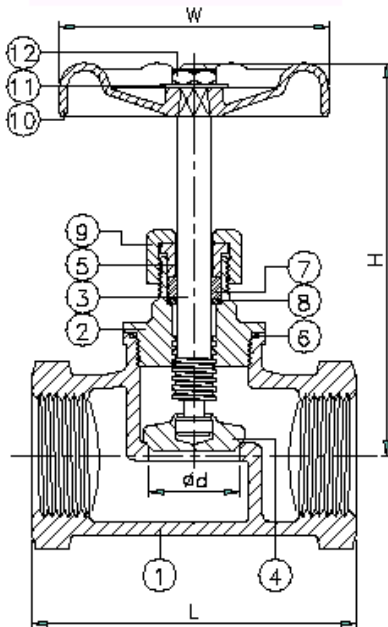

ITEM	PARTS	MATERIAL
1	BODY	ASTM A351-CF8M
2	BONNET	ASTM A351-CF8M
3	STEM	AISI 316
4	DISC	AISI 316
5	GLAND RING	AISI 304
6	GASKET	PTFE
7	PACKING	PTFE
8	WASHER	AISI 316
9	GLAND NUT	ASTM A351-CF8M
10	HAND WHEEL	SS 400
11	NAME PLATE	ALUMINUM
12	NUT	AISI 304

SIZE		1/2"	3/4"	1"	1-1/4"	1-1/2"	2"
L	in	2.48	2.76	3.03	3.43	3.94	4.33
	mm	63	70	77	87	100	110
H	in	4.17	4.17	4.57	4.80	5.67	5.71
	mm	106	106	116	122	144	145
W	in	2.44	2.44	2.95	2.95	3.74	3.74
	mm	62	62	75	75	95	95
Weight	lb	0.9	1	1.4	2.3	3.1	4.6
	kg	0.4	0.5	0.7	0.9	1.35	1.65
Cv		3.8	7	11	21	29	50

PMP Precision Valve Company Ltd. Is a progressive supplier of current products. The features, materials of construction and dimensional data as detailed in this bulletin are intended for your reference only, and should not be relied upon unless confirmed in writing by PMP Precision Valve Co. Ltd.. Certified dimensional drawings are available upon order receipt.