



# Gate Valve

**2029**  
200 WOG  
1/2" - 3"

Non-Rising Stem

Screwed Bonnet

Threaded ends conform to ASME B1.20.1 (NPT)

Metal X Metal Seat

- Investment Cast Body
- Max working pressure 200psi CWP

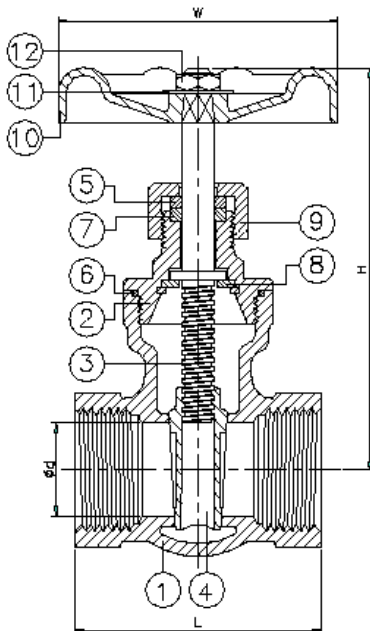

ITEM	PARTS	MATERIAL
1	BODY	ASTM A351-CF8M
2	BONNET	ASTM A351-CF8M
3	STEM	AISI 316
4	DISC	ASTM A351-CF8M
5	GLAND RING	AISI 316
6	GASKET	PTFE
7	PACKING	PTFE
8	SNAP RING	AISI 304
9	GLAND NUT	ASTM A351-CF8M
10	HAND WHEEL	SS 400
11	NAME PLATE	ALUMINUM
12	NUT	AISI 304

SIZE		1/2"	3/4"	1"	1-1/4"	1-1/2"	2"	2-1/2"	3"
L	in	2.24	2.40	2.72	3.09	3.21	3.72	4.57	5.16
	mm	57	61	69	78.5	81.5	94.5	116	131
H	in	3.94	3.94	4.84	5.31	5.91	6.69	10.24	11.61
	mm	100	100	123	135	150	170	260	295
W	in	2.44	2.44	2.95	2.95	3.74	3.74	4.72	4.72
	mm	62	62	75	75	95	95	120	120
Weight	lb	0.88	1.10	1.65	2.42	3.19	4.62	10.12	15.40
	kg	0.4	0.5	0.75	1.1	1.45	2.1	4.6	7
Cv		17.6	32	54	97	135	230	400	600

PMP Precision Valve Company Ltd. Is a progressive supplier of current products. The features, materials of construction and dimensional data as detailed in this bulletin are intended for your reference only, and should not be relied upon unless confirmed in writing by PMP Precision Valve Co. Ltd.. Certified dimensional drawings are available upon order receipt.