



Swing Check Valve

2030
600 WOG
1/2" - 2"

PTFE Gasket

Screwed in Cap

Investment Cast Body

Threaded Ends conform to:
ASME B1.20.1 (NPT)



- Max temperature 445 F
- Options:
PTFE Seat

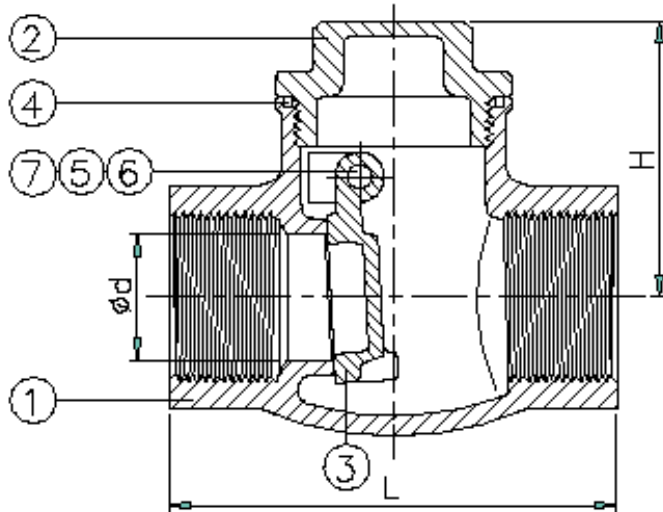

ITEM	PARTS	MATERIAL
1	BODY	ASTM A351-CF8M
2	CAP	ASTM A351-CF8M
3	DISC	ASTM A351-CF8M
4	GASKET	PTFE
5	PLUG SEAL	PTFE
6	PLUG	AISI 316
7	PIN	AISI 316

SIZE		1/2"	3/4"	1"	1-1/4"	1-1/2"	2"
L	in	2.36	3.07	3.31	3.70	4.09	4.80
	mm	60	78	84	94	104	122
H	in	1.63	1.81	1.93	2.11	2.30	2.64
	mm	41.5	46	49	53.5	58.5	67
WEIGHT	lb	0.6	1.2	1.5	1.9	2.6	4.0
	kg	0.29	0.53	0.69	0.85	1.2	1.8
Cv		6.9	16.3	30	49	72	130

PMP Precision Valve Company Ltd. Is a progressive supplier of current products. The features, materials of construction and dimensional data as detailed in this bulletin are intended for your reference only, and should not be relied upon unless confirmed in writing by PMP Precision Valve Co. Ltd.. Certified dimensional drawings are available upon order receipt.