



# 2 Piece Ball Valve Full Port

**A201**  
1000 WOG  
1/4" – 3" NPT

Adjustable PTFE Packing

Investment Cast Body  
CF8M Body

PTFE Body Seal

**Full Bore** Design



Stainless Steel  
Latch Lock Handle

Blow-out Proof Stem

Solid Ball & Stem

Bi-Directional  
RPTFE Seats

### Pressure Rating

- 1/4" – 2" 1000 WOG
- 2-1/2" – 3" 800 WOG

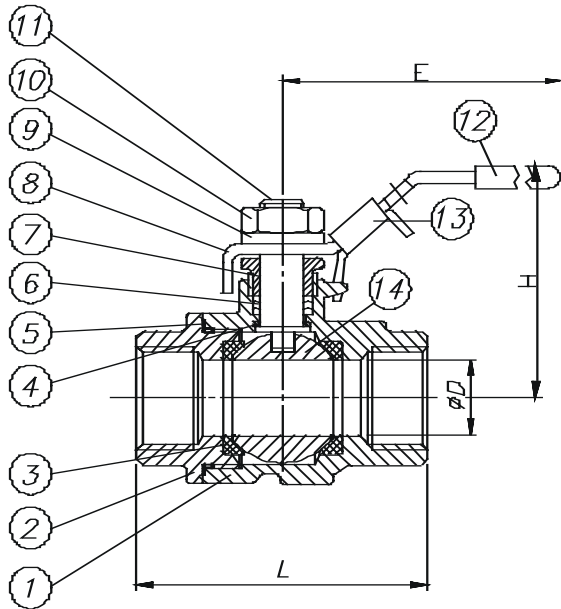

NO	PART NAME	QTY	SPECIFICATION	
1	BODY	1	WCB	CF8M
2	END CAP	1	WCB	CF8M
3	SEATS	2	RPTFE	RPTFE
4	THRUST WASHER	1	PTFE	PTFE
5	BODY GASKET	1	PTFE	PTFE
6	STEM PACKING	3	PTFE	PTFE
7	PACKING GLAND	1	SS304	SS304
8	HANDLE	1	C.S.	SS304
9	HANDLE WASHER	1	C.S.	SS304
10	HANDLE NUT	1	C.S.	SS304
11	STEM	1	SS304	SS316
12	HANDLE SLEEVE	1	PLASTIC	PLASTIC
13	LOCKING DEVICE	1	C.S.	SS304
14	BALL	1	SS304	SS316

SIZE		1/4"	3/8"	1/2"	3/4"	1"	1-1/4"	1-1/2"	2"	2-1/2"	3"
D	in	0.46	0.50	0.50	0.75	1.00	1.25	1.50	2.00	2.50	3.00
	mm	10	12	15	20	25	32	40	50	65	80
L	in	2.13	2.13	2.68	3.03	3.58	3.98	4.25	4.88	7.28	8.07
	mm	54	54	68	77	91	101	108	124	185	205
H	in	2.32	2.32	2.36	2.91	3.03	3.43	3.66	4.21	5.71	6.10
	mm	59	59	60	74	77	87	93	107	145	155
E	in	4.49	4.49	4.49	5.43	5.43	7.28	7.68	7.68	10.24	10.24
	mm	114	114	114	138	138	185	195	195	260	260