



Needle Valve

2032

6000 psi
1/4" - 1" NPT

Threaded ends conform to:
ASME B1.20.1(NPT)

Forged AISI 316
Stainless Steel Body



Stainless Steel
handle

PTFE Adjustable
Packing

Metal Seats

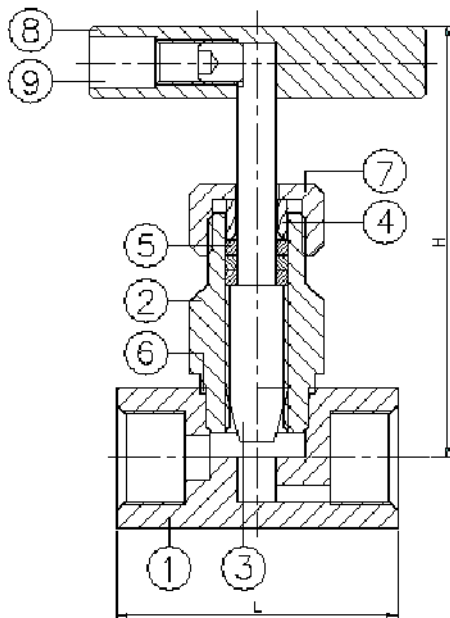

ITEM	PARTS	MATERIAL
1	BODY	AISI 316
2	BONNET	AISI 316
3	STEM	AISI 316
4	GLAND RING	AISI 316
5	PACKING	PTFE
6	GASKET	PTFE
7	GLAND NUT	AISI 316
8	HANDLE	AISI 410
9	LOCK BOLT	AISI 304

SIZE		1/4"	3/8"	1/2"	3/4"	1"
L	in	2.28	2.28	2.56	2.76	3.15
	mm	58	58	65	70	80
H	in	2.95	2.95	3.43	3.54	4.06
	mm	75	75	87	90	103
Weight	LB	0.6	0.7	1.2	1.4	3.1
	KG	0.27	0.33	0.54	0.65	1.4
Cv		0.5	0.5	1.8	2	3

PMP Precision Valve Company Ltd. Is a progressive supplier of current products. The features, materials of construction and dimensional data as detailed in this bulletin are intended for your reference only, and should not be relied upon unless confirmed in writing by PMP Precision Valve Co. Ltd.. Certified dimensional drawings are available upon order receipt.