



Flanged Swing Check Valve

2024
ANSI 150
2" - 12"



Stainless Steel
Body

Metal Seat

Flanged Ends conform to:
ANSI B16.5

Face to Face:
ANSI B 16.10

- Wall thickness: ANSI B 16.34
 - Tested to API 598
- Options:**
Resilient Seat
Lever & Weight
Wafer Design

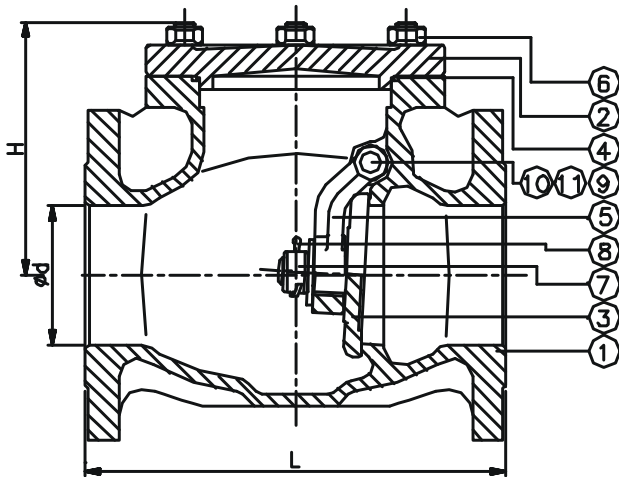

ITEM	PARTS	MATERIAL
1	BODY	ASTM A351-CF8M
2	COVER	ASTM A351-CF8M
3	DISC	ASTM A351-CF8M
4	GASKET	PTFE
5	LEVER	ASTM A351-CF8M
6	COVER STUD	ASTM A193-B8
7	DISC NUT	ASTM A194-8M
8	SPLIT PIN	AISI 316
9	HINGE PIN	AISI 316
10	GASKET PLUG	PTFE
11	PLUG	AISI 316

SIZE		1"	1-1/2"	2"	2-1/2"	3"	4"	6"	8"	10"	12"
d	in	1"	1-1/2"	2"	2-1/2"	3"	4"	6"	8"	10"	12"
	mm	25	40	50	65	80	100	150	200	250	300
L	in	5.31	6.5	8	8.5	9.5	11.5	14	19.5	24.5	27.5
	mm	135	165	203	216	241	292	356	495	622	699
H	in	2.76	4.09	5.31	6.5	7.09	8.27	10.43	12.6	13.98	16.14
	mm	70	104	135	165	180	210	265	320	355	410

PMP Precision Valve Company Ltd. Is a progressive supplier of current products. The features, materials of construction and dimensional data as detailed in this bulletin are intended for your reference only, and should not be relied upon unless confirmed in writing by PMP Precision Valve Co. Ltd.. Certified dimensional drawings are available upon order receipt.