



Nace Ball Valve 2 Piece Full Port*

A206

6000 PSI
1/4" - 2"

Graphite Packing

Actuator Mounting

Heavy Duty Investment
Cast CF8M Body

BI-Directional
Delrin Seats



Stainless Steel Latch
Lock Handle

Blow-out proof 316
Stainless Steel stem

NPT Ends conform to
ANSI B1.20.1

Solid 316 Stainless
Steel Ball

- 1/4" - 1-1/2" Full Port
- *2" Reduced Port

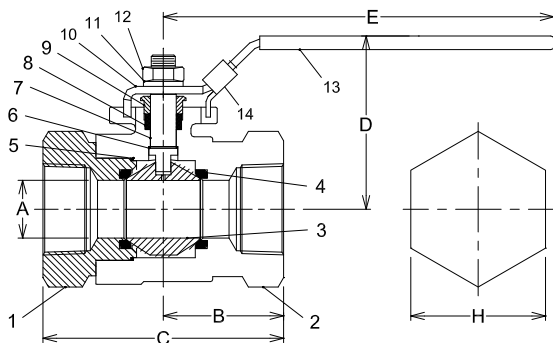
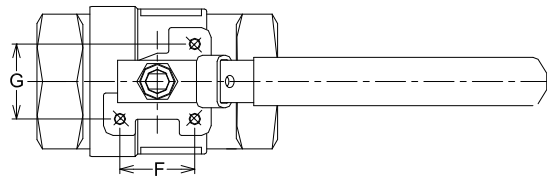

ITEM	PARTS	MATERIAL	
1	CAP	CF8M	WCB
2	BODY	CF8M	WCB
3	BALL	CF8M	CF8
4	SEAT	DELTRIN	DELTRIN
5	GASKET	PTFE	PTFE
6	THRUST WASHER	PTFE+15%GF	PTFE+15%GF
7	STEM	SS 316	SS 316
8	STEM PACKING	GRAPHITE	GRAPHITE
9	GLAND NUT	A194 GR.8	A194 GR.8
10	HANDLE	SS 304	SS 304
11	SPRING WASHER	SS 304	SS 304
12	STEM NUT	A194 GR.8	A194 GR.8
13	HANDLE COVER	PLASTIC	PLASTIC
14	LOCKING DEVICE	SS 304	SS 304

SIZE	1/4"	3/8"	1/2"	3/4"	1"	1-1/4"	1-1/2"	2"	
A	IN	0.31	0.47	0.59	0.79	0.98	1.26	1.57	
	MM	8	12	15	20	25	32	40	
B	IN	1.50	1.50	1.97	2.13	2.24	2.38	3.11	
	MM	38	38	50	54	57	60.5	79	
C	IN	2.99	2.99	3.98	4.25	4.53	4.76	6.22	
	MM	76	76	101	108	115	121	158	
D	IN	2.20	2.20	2.20	2.72	3.50	4.92	4.49	
	MM	56	56	56	69	89	125	114	
E	IN	4.96	4.96	4.96	6.22	8.15	8.15	10.12	
	MM	126	126	126	158	207	207	257	
F	IN	1.00	1.00	1.00	1.18	1.40	1.40	1.95	
	MM	25.5	25.5	25.5	30	35.5	35.5	49.5	
G	IN	1.00	1.00	1.00	1.18	1.40	1.40	1.95	
	MM	25.5	25.5	25.5	30	35.5	35.5	49.5	
	IN	1.25	1.25	1.25	1.81	2.25	2.76	3.50	
	MM	31.8	31.8	31.8	46.1	57.2	70	88.9	
T		No. 12 -24UNC				1/4-20UNC		5/16-18UNC	

PMP Precision valve Company Ltd. Is a progressive supplier of current products. The features, materials of construction and dimensional data as detailed in this bulletin are intended for your reference only, and should not be relied upon unless confirmed in writing by PMP Precision Valve Co. Ltd.. Certified dimensional drawings are available upon order receipt.