

TILTING DISC CHECK VALVE **SERIES R**

ANSI 150 PRESSURE CLASS



FEATURES

- Cast One Piece Wafer Body
- CF8M or WCB Construction
- API 594 Face to Face
- Hard Faced Seats

OPTIONS:

- Outside Lever and Weight
- Hydraulic Shock Absorber

ITEM	DESCRIPTION	MATERIAL	MATERIAL
1	BODY	A-216 WCB + 304	CF8M
2	DISC	A-216 WCB + 304	CF8M
3	SHAFT	AISI 420	AISI 420
4	PLUG	F-111	AISI 304
* 5	COUNTERWEIGHT	CARBON STEEL	CARBON STEEL
* 6	HYDRAULIC SHOCK ABSORBER		

* OPTION

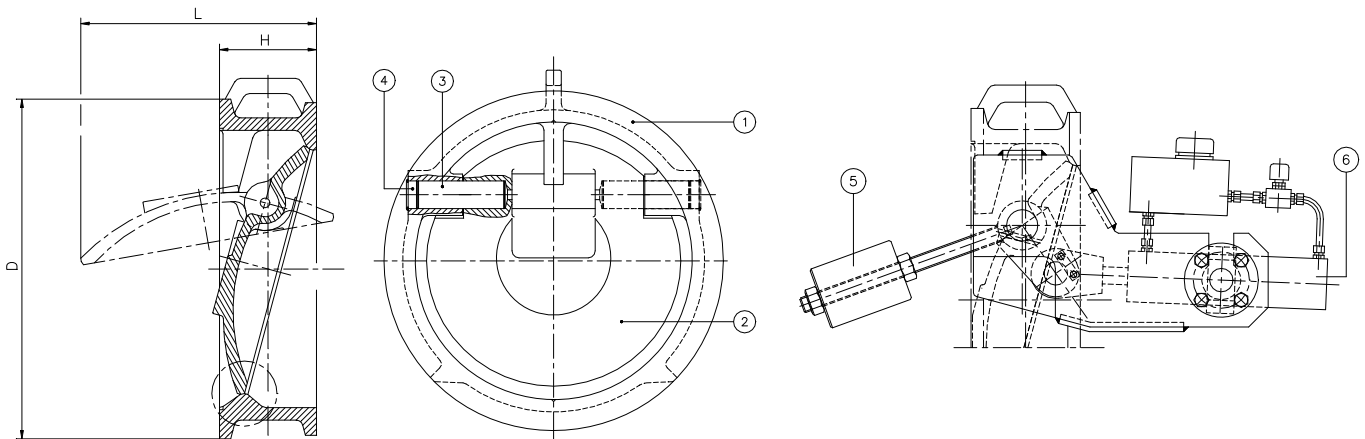

SIZE		2"	3"	4"	5"	6"	8"	10"	12"	14"
d	in	1.73	2.83	3.54	4.41	5.31	7.09	8.86	10.63	12.40
	mm	44	72	90	112	135	180	225	270	315
H	in	2.36	2.88	2.88	3.25	3.88	5.00	5.75	7.13	7.25
	mm	60	73	73	89	98	127	146	181	184
L	in	2.36	3.54	4.02	4.72	5.51	7.28	8.66	10.31	12.20
	mm	60	90	102	120	140	185	220	262	310

PMP Precision Valve Company Ltd. Is a progressive supplier of current products. The features, materials of construction and dimensional data as detailed in this bulletin are intended for your reference only, and should not be relied upon unless confirmed in writing by PMP Precision Valve Co. Ltd.. Certified dimensional drawings are available upon order receipt.