

# M-302

## 3 Piece Full Port Ball Valve

1/2"-2" 1500 WOG  
2-1/2" - 4" 800 WOG

**Locking Tab Washer**  
Keeps Lock nut from loosening in High Cycle Automated Applications

**ISO 5211 Mounting Pad**  
Allows Direct Actuator Mounting Eliminating Costly Brackets - Adapters

**Bi-Directional RPTFE Seats**

**PTFE Thrust Washer**

**Full Bore**

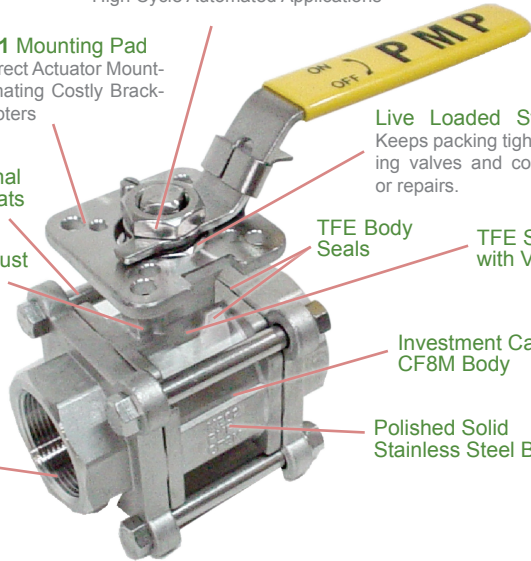

**Live Loaded Stem Packing**  
Keeps packing tight avoiding leaking valves and costly shutdowns or repairs.

**TFE Body Seals**

**TFE Stem Packing with Viton O-Ring**

**Investment Cast CF8M Body**

**Polished Solid Stainless Steel Ball**

**Blow-Out Proof Stem Swing out Valve Body**  
1/2"-2" 1500 WOG  
2-1/2"-4" 800 WOG

NO	PART NAME	QTY	SPECIFICATION
1	Body	1	ASTM A351 GR. CF8M
2	Bolt	4	SS304
3	Cap	2	ASTM A351 GR. CF8M
4	Seats	2	PTFE
5	Gasket	1	PTFE
6	Thrust Washer	2	PTFE
7	Stem Packing	2	PTFE
8	Gland	1	SS304
9	Spring	2	SS301
10	Nut	1	SS304
11	Handle	1	SS304
12	Nut	1	SS304
13	Cover	1	Plastic
14	Tab Washer	1	SS304
15	Stem	1	SS316
16	O-Ring	1	VITON
17	Nut	4	SS304
18	Ball	1	SS316
19	Stop	1	SS304

Size		1/2"	3/4"	1"	1-1/4"	1-1/2"	2"	2-1/2"	3"	4"
D	in	0.50	0.75	1.00	1.25	1.50	2.00	2.50	3.00	4.00
	mm	15	20	25	32	40	50	65	80	100
U	in	0.35	0.43	0.43	0.43	0.43	0.55	0.67	0.67	0.75
	mm	9	11	11	11	11	14	17	17	19
H	in	2.95	3.11	3.19	3.54	4.21	4.21	5.08	6.50	6.61
	mm	75	79	81	90	107	107	129	165	168
A1 NPT	in	0.50	0.75	1.00	1.25	1.50	2.00	2.50	3.00	4.00
	mm	13	19	25	32	38	51	64	76	102
L	in	2.95	3.15	3.54	4.33	4.72	5.51	7.28	8.07	9.45
	mm	75	80	90	110	120	140	185	205	240
E	in	4.49	5.24	5.24	7.36	7.36	8.74	12.40	12.40	12.40
	mm	114	133	133	187	187	222	315	315	315
<b>ISO 5211</b>		F03/F04	F04	F04	F04	F05/F07	F05	F07	F07	F10

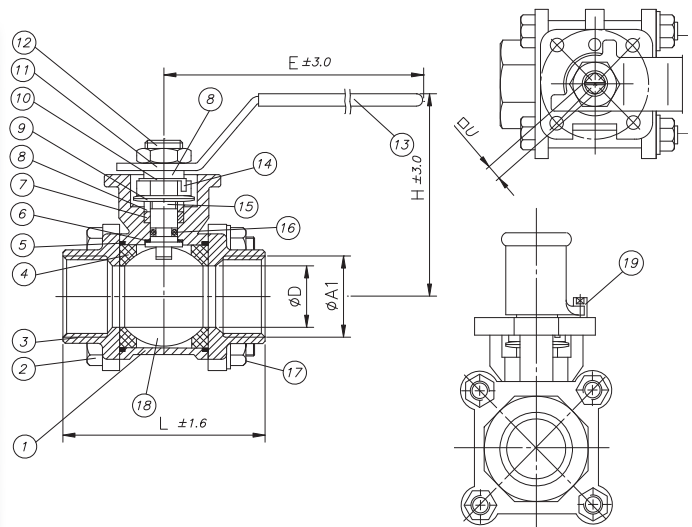

**PMP Precision Valve Co. Ltd.**  
3464 Poirier boulevard  
Saint Laurent, Qc, H4R 2J5

Email: [info@pmpvalve.com](mailto:info@pmpvalve.com)  
Tel: 514 331 0729  
Fax: 514 331 9849