

ITEM NO.	QTY.	DESCRIPTION	Material
1	1	BODY	ASTM A351 GR. CF8M
2	1	END CAP	ASTM A351 GR. CF8M
3	1	BODY GASKET	SS304+GRAPHITE
4	1	BALL	SS316
5	2	SEAT	TFM1600
6	1	STEM	SS316
7	1	THRUST WASHER	MG1241
8	1	O-RING	VITON
9	1	PACKING	GRAPHITE
10	2	PACKING GLAND	SS304
11	1	DISC SPRING	SS301
12	1	SPACER	SS304
13	1	HANDLE	SS304
14	1	COVER	PLASTIC
15	1	YOKE	SS304
16	1	HANDLE NUT	A4-70
17	2	YOKE SCREW	A4-70
18	1	STOPPER	A4-70
19	2	NUT	A4-70
20	4	HEX BOLT	A4-70
21	1	STOPPER NUT	A4-70

UNLESS OTHERWISE SPECIFIED:		NAME	DATE	 PMP PRECISION VALVE CO. LTD. www.pmpvalve.com
DIMENSIONS ARE IN INCHES		DRAWN	John VuLcu 11/10/2023	
TOLERANCES:		CHECKED	Sean McAleer 11/10/2023	TITLE: DN15 BALL VALVE MODEL: M230 CLASS 300 GENERAL ASSEMBLY
FRACTIONAL ±		ENG APPR.		
ANGULAR: MACH ± BEND ±		MFG APPR.		
TWO PLACE DECIMAL ±		Q.A.		
THREE PLACE DECIMAL ±		COMMENTS:		SIZE B DWG. NO. M230 - DN15 REV 0
INTERPRET GEOMETRIC TOLERANCING PER:				SCALE: 1:1.5 WEIGHT:
MATERIAL				SHEET 1 OF 2
FINISH				
DO NOT SCALE DRAWING				

PROPRIETARY AND CONFIDENTIAL

THE INFORMATION CONTAINED HEREIN SHALL NOT BE COPIED, TRANSFERRED, CONVEYED OR DISPLAYED IN ANY MANNER THAT WOULD VIOLATE ITS PROPERTY NATURE WITHOUT THE EXPRESS WRITTEN PERMISSION OF PMP PRECISION VALVE INC. 3530 Boul. Poirier St. Laurent, Quebec, H4R 2J5

8 7 6 5 4 3 2 1

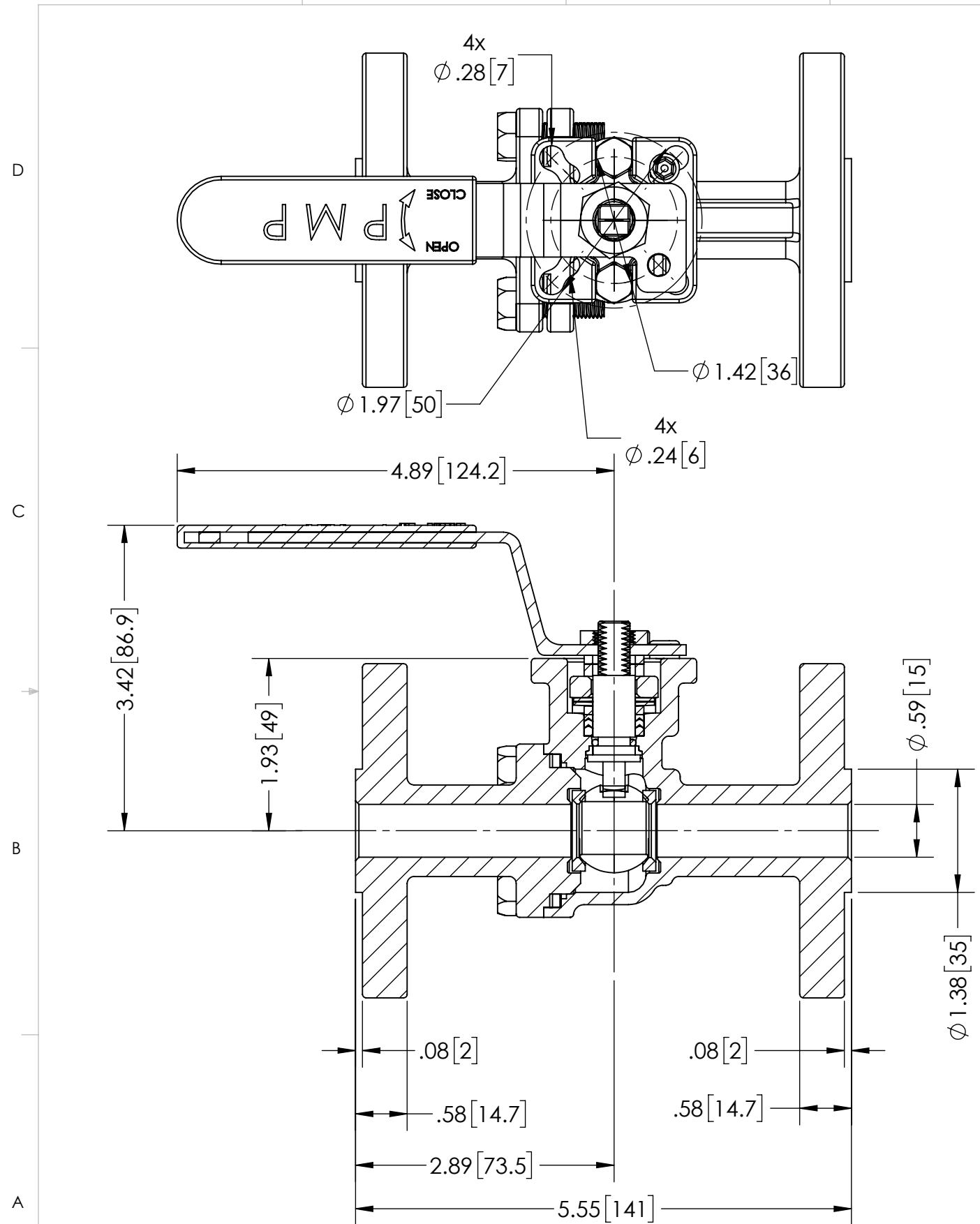

SECTION A-A

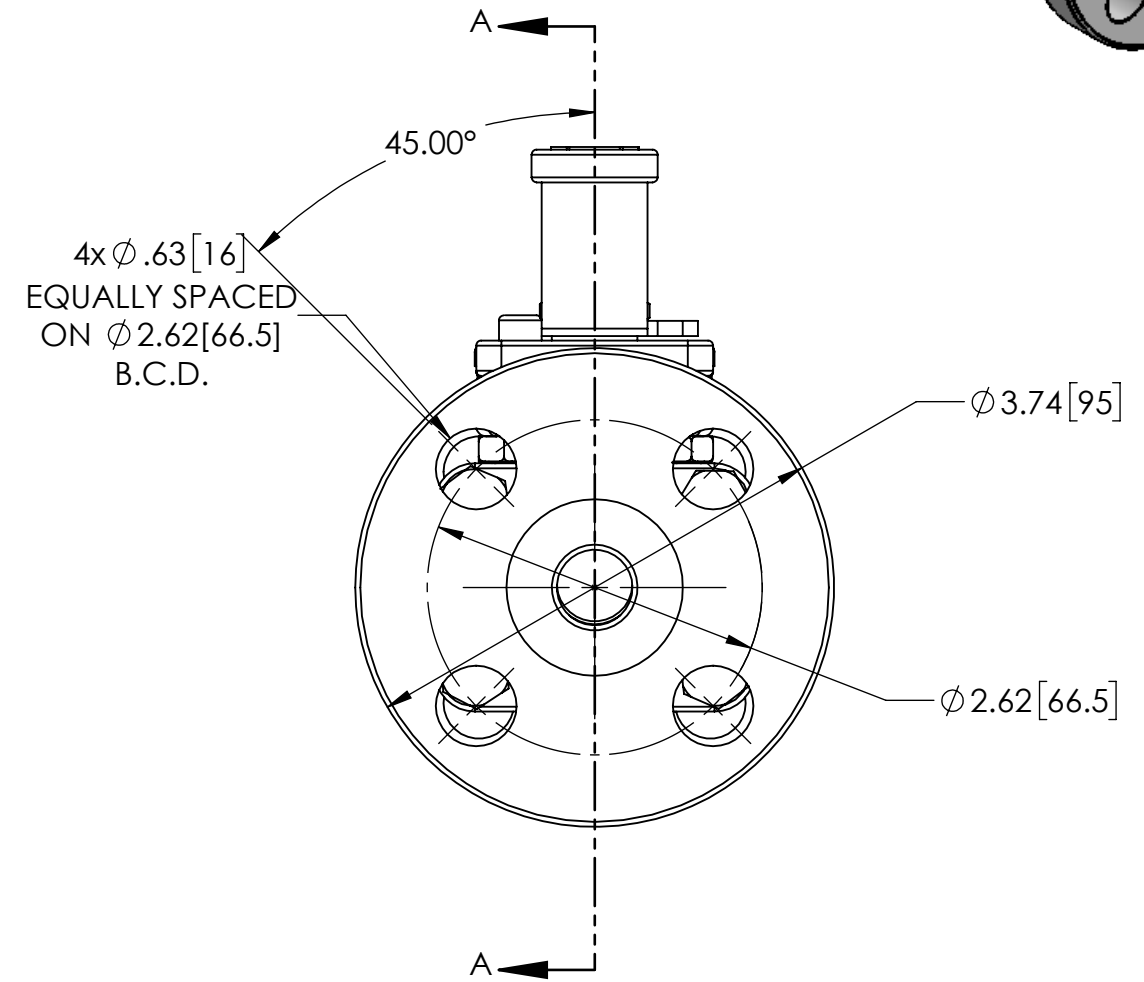
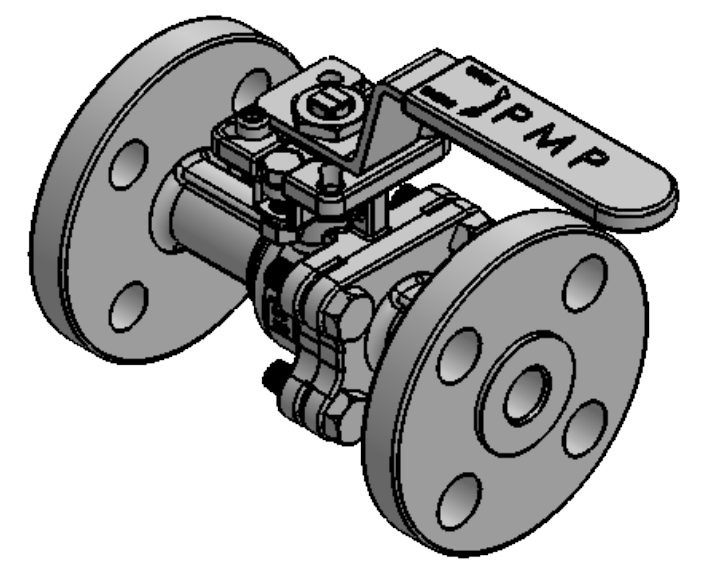

PROPRIETARY AND CONFIDENTIAL

THE INFORMATION CONTAINED HEREIN SHALL NOT BE COPIED, TRANSFERRED, CONVEYED OR DISPLAYED IN ANY MANNER THAT WOULD VIOLATE ITS PROPERTY NATURE WITHOUT THE EXPRESS WRITTEN PERMISSION OF PMP PRECISION VALVE INC. 3530 Boul. Poirier St. Laurent, Quebec, H4R 2J5

UNLESS OTHERWISE SPECIFIED:		NAME	DATE	PMP PRECISION VALVE CO LTD. www.pmpvalve.com	
DIMENSIONS ARE IN INCHES		DRAWN	John VuLcu		11/10/2023
TOLERANCES:		CHECKED	Sean McAleer		11/10/2023
FRACTIONAL ±		ENG APPR.			
ANGULAR: MACH ± BEND ±		MFG APPR.			
TWO PLACE DECIMAL ±		Q.A.			
THREE PLACE DECIMAL ±		COMMENTS:			
INTERPRET GEOMETRIC TOLERANCING PER:					
MATERIAL					
FINISH					
DO NOT SCALE DRAWING					

TITLE:		
DN15 BALL VALVE		
MODEL: M230 CLASS 300		
GENERAL ASSEMBLY		
SIZE	DWG. NO.	REV
B	M230 - DN15	0
SCALE: 1:1.5 WEIGHT:		SHEET 2 OF 2

8 7 6 5 4 3 2 1