

ITEM NO.	QTY.	DESCRIPTION	Material
1	1	BODY	ASTM A315 GR.CF8M
2	1	END CAP	ASTM A315 GR.CF8M
3	1	BODY GASKET	SS304+GRAPHITE
4	1	BALL	SS316
5	2	SEAT	TFM1600
6	1	STEM	SS316
7	1	THRUST WASHER	MG1241
8	1	O-RING	VITON
9	1	PACKING	GRAPHITE
10	1	PACKING GLAND	SS304
11	1	DISC SPRING	SS301
12	1	YOKE	SS304
13	1	SPACER	SS304
14	1	WASHER	SS304
15	1	HANDLE	SS304
16	1	COVER	PLASTIC
17	1	HANDLE NUT	A4-70
18	1	HANDLE SCREW	A4-70
19	1	STOPPER	SS304
20	3	NUT	A4-70
21	2	YOKE SCREW	A4-70
22	4	HEX BOLT	A4-70

PROPRIETARY AND CONFIDENTIAL

THE INFORMATION CONTAINED HEREIN SHALL NOT BE COPIED, TRANSFERRED, CONVEYED OR DISPLAYED IN ANY MANNER THAT WOULD VIOLATE ITS PROPERTY NATURE WITHOUT THE EXPRESS WRITTEN PERMISSION OF PMP PRECISION VALVE INC. 3530 Boul. Poirier St. Laurent, Quebec, H4R 2J5

UNLESS OTHERWISE SPECIFIED:		NAME	DATE	 PMP PRECISION VALVE CO LTD. www.pmpvalve.com
DIMENSIONS ARE IN INCHES		DRAWN	John Vulcu 11/10/2023	
TOLERANCES:		CHECKED	Sean McAleer 11/10/2023	TITLE:
FRACTIONAL ±		ENG APPR.		DN25 BALL VALVE
ANGULAR: MACH ± BEND ±		MFG APPR.		MODEL: M230 CLASS 300
TWO PLACE DECIMAL ±		Q.A.		GENERAL ASSEMBLY
THREE PLACE DECIMAL ±		COMMENTS:		SIZE DWG. NO. REV
INTERPRET GEOMETRIC TOLERANCING PER:				B M230 - DN25 0
MATERIAL				SCALE: 1:1.5 WEIGHT: SHEET 1 OF 2
FINISH				
DO NOT SCALE DRAWING				

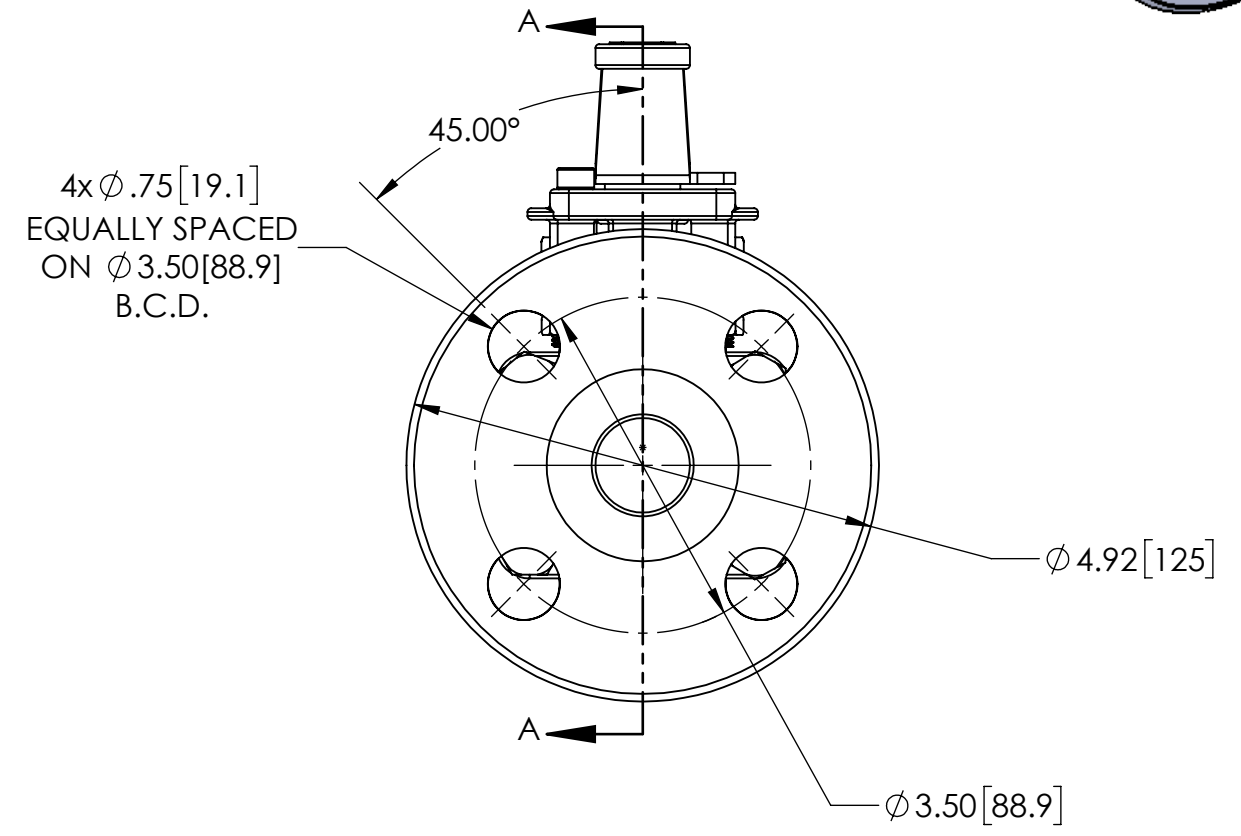
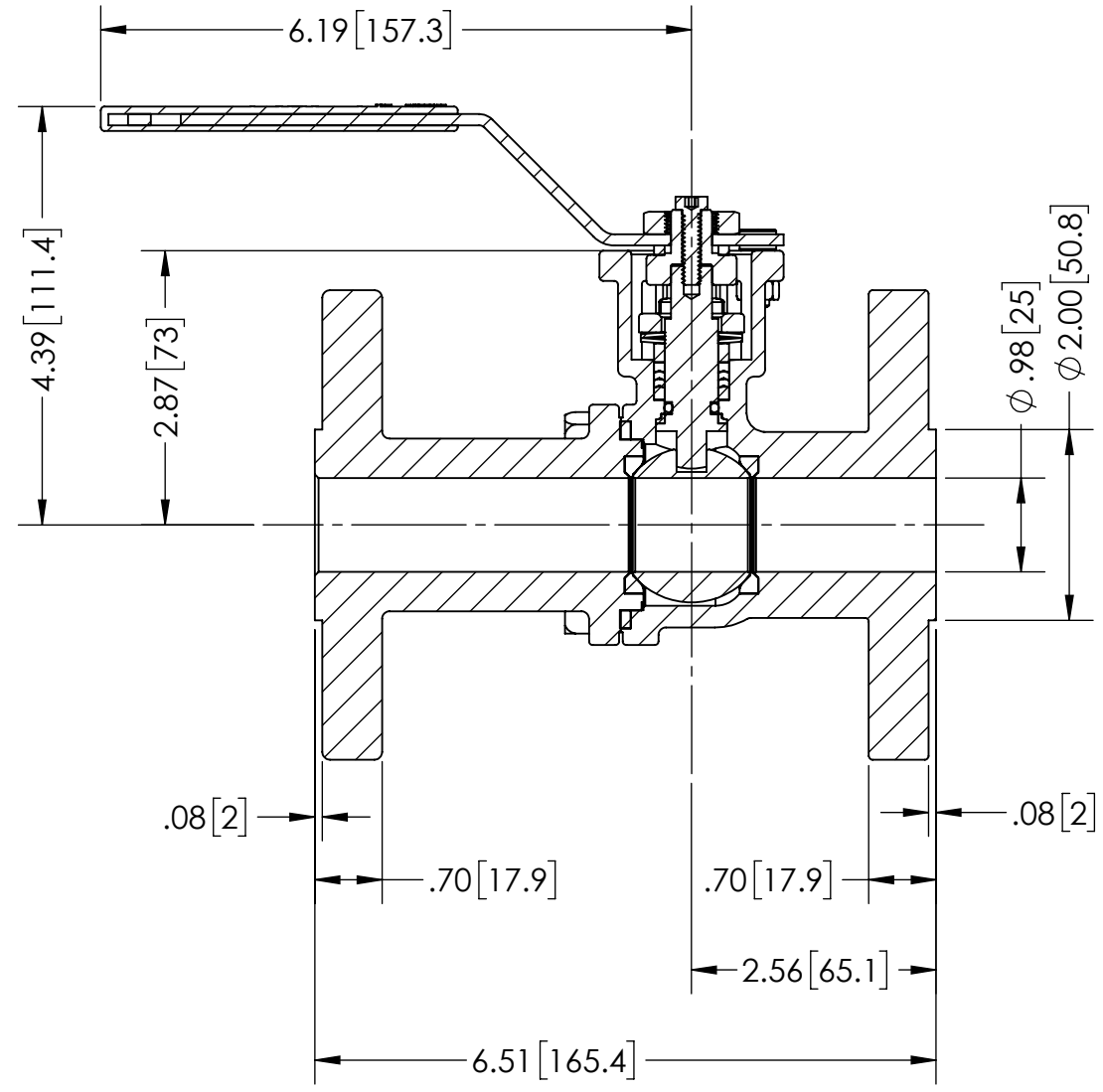
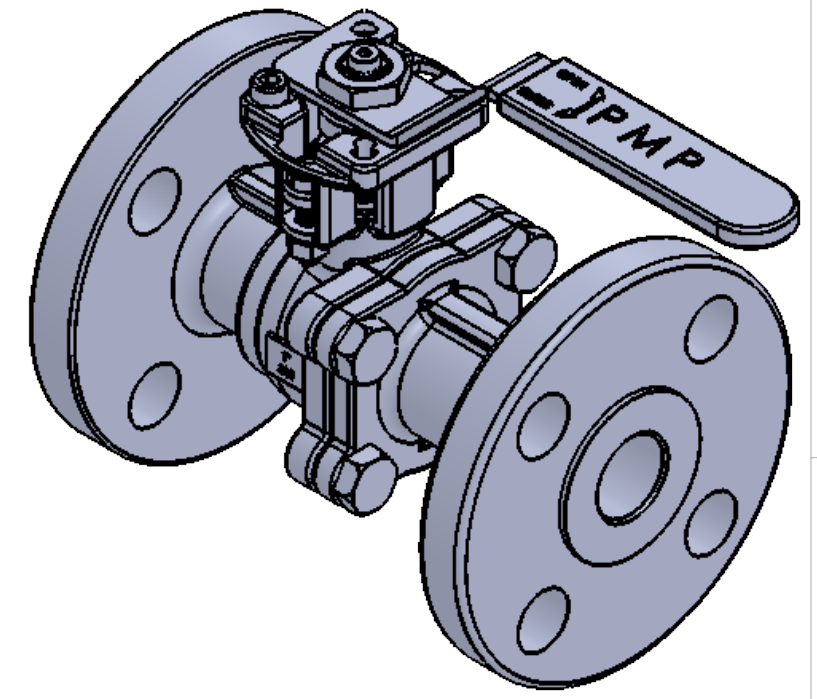
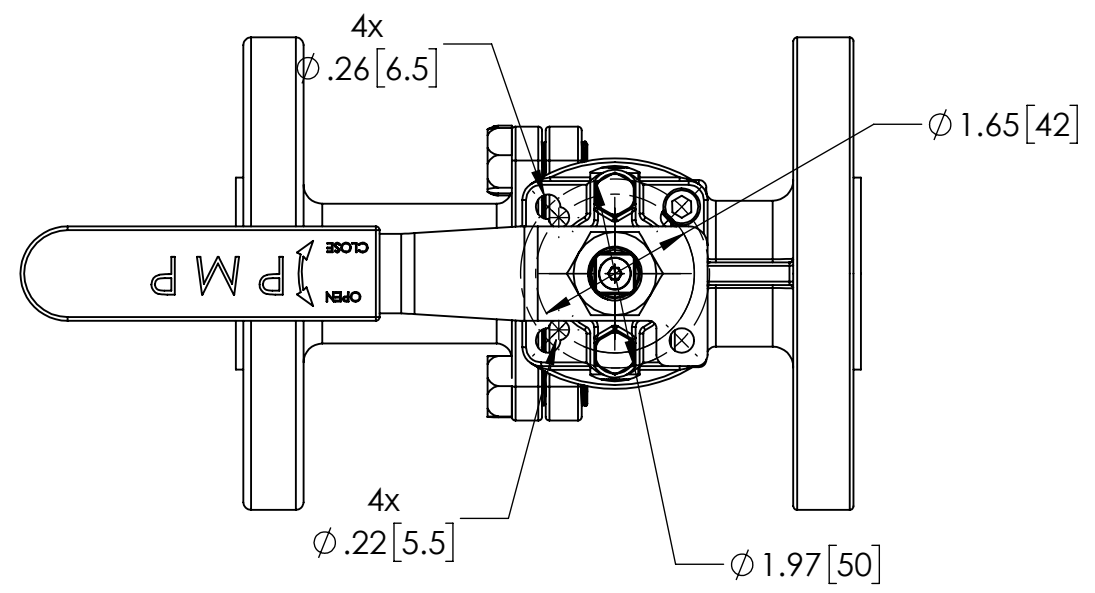

SECTION A-A

PROPRIETARY AND CONFIDENTIAL
 THE INFORMATION CONTAINED HEREIN SHALL NOT BE COPIED, TRANSFERRED, CONVEYED OR DISPLAYED IN ANY MANNER THAT WOULD VIOLATE ITS PROPERTY NATURE WITHOUT THE EXPRESS WRITTEN PERMISSION OF PMP PRECISION VALVE INC. 3530 Boul. Poirier St. Laurent, Quebec, H4R 2J5

UNLESS OTHERWISE SPECIFIED:		NAME	DATE	 PMP PRECISION VALVE CO LTD. www.pmpvalve.com
DIMENSIONS ARE IN INCHES		DRAWN	John Vulcu 11/10/2023	
TOLERANCES:		CHECKED	Sean McAleer 11/10/2023	TITLE:
FRACTIONAL ±		ENG APPR.		DN25 BALL VALVE
ANGULAR: MACH ± BEND ±		MFG APPR.		MODEL: M230 CLASS 300
TWO PLACE DECIMAL ±		Q.A.		GENERAL ASSEMBLY
THREE PLACE DECIMAL ±		COMMENTS:		SIZE DWG. NO. REV
INTERPRET GEOMETRIC TOLERANCING PER:				B M230 - DN25 0
MATERIAL				SCALE: 1:2 WEIGHT: SHEET 2 OF 2
FINISH				
DO NOT SCALE DRAWING				