



PMP PRECISION VALVE CO. LTD.

www.pmpvalve.com



PMP / FSK BALL CHECK Valve

**Model 2055
2" - 20"**

PMP | FSK Ball Check Valve

- Featuring low head loss, the PMP sinking ball check valve is normally installed for sewage applications to prevent back flow.
- Valves can be installed for either horizontal or vertical applications.
- The sinking ball automatically cleans itself and offers tight shut-off.
- The body cover is easy to disassemble for quick maintenance.

DESIGN SPECIFICATIONS

Size Range:	2" - 20"
Design Standard:	EN1074-3
Flange dimension:	ASME B16.5 Cl. 125
Face to Face:	EN558 series 48
Test & Inspection:	EN12266-1
Working Pressure:	150 PSI
Maximum Temperature:	80 deg C, 176 deg



PMP | FSK Ball Check Valve

2" - 20"

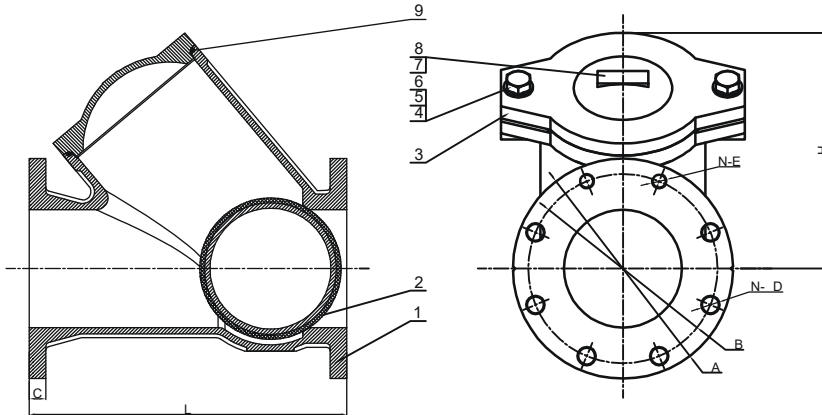

Material Specification

SR.No.	Description	Material
1	Body	Ductile Iron
2	Ball Coated Rubber	Steel / Ductile Iron+NBR
3	Cover	Ductile Iron
4	Hex Bolt	Stainless Steel SS304
5	Gasket	Stainless Steel SS304
6	Nut	Stainless Steel SS304
7	Nameplate	Stainless Steel SS304
8	Rivet	AL
9	O Ring	NBR

Inches	C	L	ØA	ØB	N-ØD	N-E	H
2	15.9	200	Ø150	Ø121	4-Ø19.1	-	122
2.5	17.5	240	Ø180	Ø140	4-Ø19.1	-	143
3	19	260	Ø190	Ø152	4-Ø19.1	-	168
4	23.8	300	Ø230	Ø191	6-Ø19.1	2-(5/8-11UNC)	202
5	23.8	350	Ø255	Ø216	8-Ø22.4	-	251
6	25.4	400	Ø280	Ø241	8-Ø22.4	-	300
8	28.6	500	Ø345	Ø299	6-Ø22.4	2-(3/4-10UNC)	387
10	30.2	600	Ø405	Ø362	10-Ø25.4	2-(7/8-9UNC)	435
12	31.8	700	Ø485	Ø432	10-Ø25.4	2-(7/8-9UNC)	520

Technical Requirements:

1. Design Standard: EN 1074-3
2. Connection Flange: ASME B16.1 Class 125
3. Face to Face: EN558-1 series 48
4. Test and Inspection Standard: EN12266-1
5. Working Pressure: 150PSI

Material Specification

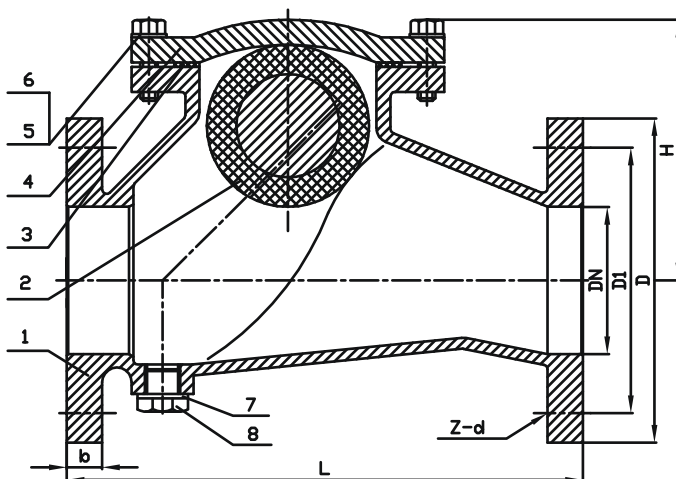

SR.No.	Description	Material
1	Body	Ductile Iron
2	Ball	NBR / Steel
3	Gasket	NBR
4	Bonnet	Ductile Iron
5	Bolt	Stainless Steel SS304
6	Washer	Stainless Steel SS304
7	Washer	PTFE
8	Plug	Stainless Steel SS304

Inches	D	D1	L	b	H	Z-d
16	Ø597	Ø539.5	900	28	584	16-Ø2
20	Ø699	Ø635	1016	43	740	20-Ø3



PMP PRECISION VALVE CO. LTD.

www.pmpvalve.com

**PMP Precision Valve Co. Ltd.
3540 Poirier Boulevard
Saint Laurent, QC, H4R 2J5**

**Tel. 514-331-0729
Fax. 514-331-9849
Email. info@pmpvalve.com**

**PMP Precision Valve Co. Ltd.
1102-333 Garrett Rd.
Qualicum Beach, BC, V9K 1H4**

**Tel. 250-713-5838
Fax. 866-388-8658
Email. info@pmpvalve.com**

Distributor



FSK-0921E