

# Q-104

## 2 Piece Forged Brass Full Port Ball Valve (CSA/CGA/AGA/UL)

- Two Piece, Forged Brass Body, Full Port
- Blow-out Proof Stem
- Virgin PTFE Seats, Adjustable PTFE Packing
- NSF/ANSI 61-8
- CSA - ANSI Z2 1.15/CGA 9.1, ASME B16.44, CGA CR 91-002
- CAN/CGA 3.16, ASME B16.33 & ASME B16.38
- UL Guides YQNZ, YRBX, YRPV & YSDT
- FM Approved (1/4" - 2")
- UL Listed - 1/4" - 2"
- CSA/CGA/AGA Approved - 1/4" - 4"



NSF/ANSI 61

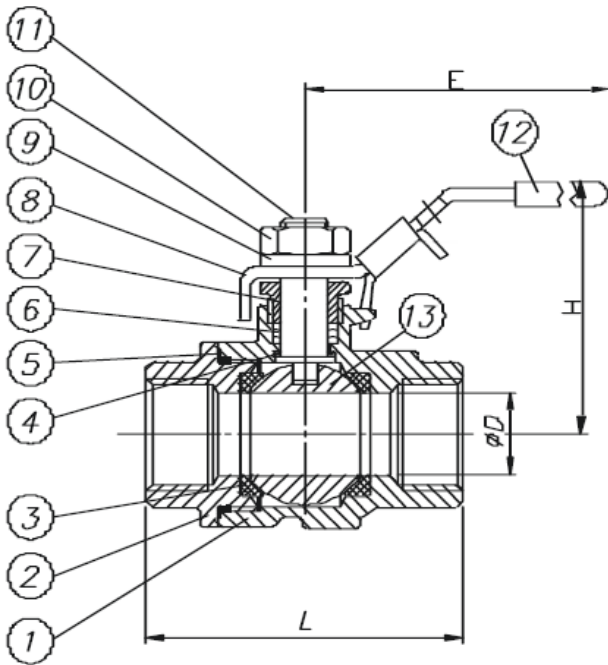

NO	DESCRIPTION	QTY	SPECIFICATION
1	Body	1	BRASS ASTM B124, UNC 37700
2	End Cap	1	BRASS ASTM B124, UNC 37700
3	Seats	2	PTFE
4	Thrust Washer	1	PTFE
5	Body Gasket	1	PTFE
6	Stem Packing	3	PTFE
7	Packing Gland	1	BRASS ASTM B124, UNC 37700
8	Handle	1	STEEL
9	Handle Washer	1	STEEL
10	Handle Nut	1	STEEL, ASTM A570 GR. A
11	Stem	1	BRASS ASTM B124, UNC 37700
12	Handle Sleeve	1	PLASTIC, YELLOW
13	Ball	1	BRASS ASTM B124, UNC 37700

### PRESSURE RATING

600 PSI wOG, 1/4" - 2"

400 PSI wOG, 2 1/2" - 4"

Size	1/4"	3/8"	1/2"	3/4"	1"	1-1/4"	1-1/2"	2"	2-1/2"	3"	4"	
D	in	0.39	0.39	0.59	0.75	0.94	1.26	1.57	1.97	2.52	2.95	3.94
	mm	10	10	15	19	24	32	40	50	64	75	100
L	in	1.77	1.77	2.05	2.36	2.76	3.31	3.66	4.17	5.38	6.04	7.40
	mm	45	45	52	60	70	84	93	106	137	153	188
H	in	1.73	1.73	1.93	2.09	2.56	2.95	3.35	3.70	4.76	5.08	5.87
	mm	44	44	49	53	65	75	85	94	121	129	149
E	in	3.54	3.54	3.54	3.78	4.53	4.53	5.51	5.51	8.66	8.66	9.61
	mm	90	90	90	96	115	115	140	140	220	220	244

