



Automatic High Cycle damper Valve

ST3

3" - 24"

Actuators direct mount

Replaceable Adjustable Packing

Discs are thru-shaft removable

Upper and Lower Roller Bearings for -40F - 1200F

- Designed to ANSI B 16.5
- Faced to 125 RMS
- Class IV Leakage
- Options:**
- High Cycle
- Resilient Seated

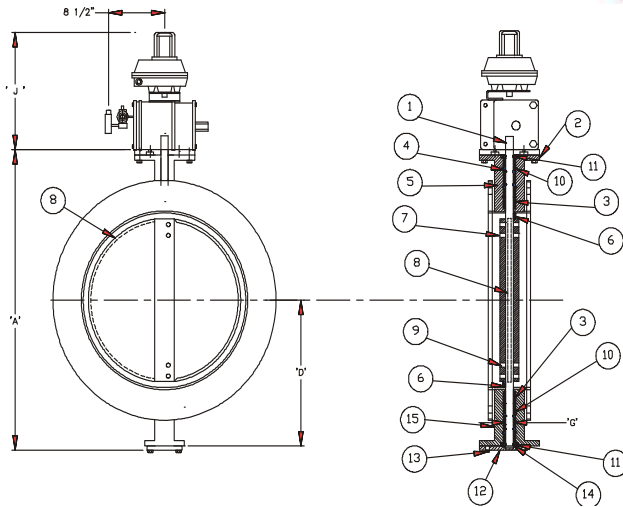

ITEM NO.	DESCRIPTION	NO. REQUIRED	MATERIAL
1	SHAFT	1	316
2	MOUNTING PLATE	1	316
3	PACKING	1	CHEVRON
4	BUSHING	1	DELTRIN
5	HUB	1	316
6	SEAT	1	S.S. / VITON
7	DISC PINS	1	TANGENTIAL
8	DISC	1	316
9	DISC PINS	1	TANGENTIAL
10	BUSHING	1	DELTRIN
11	ROLLER BEARING	1	PER. LUBRICATED
12	HUB COVER	1	316
13	MOUNTING BOLTS	1	316
14	RETAINING CLIP	1	316
15	BODY	1	S.S.

SIZE		3"	4"	5"	6"	8"	10"	12"	14"	16"	18"	20"	24"
A	in	11.50	12.50	13.50	14.50	17.00	21.50	24.50	26.50	29.00	30.50	33.00	37.50
	mm	292.1	317.5	342.9	368.3	431.8	546.1	622.3	673.1	736.6	774.7	838.2	952.5
J	in	10.50	10.50	10.50	10.50	10.50	11.50	11.50	11.50	11.50	13.50	13.50	13.50
	mm	266.7	266.7	266.7	266.7	266.7	292.1	292.1	292.1	292.1	342.9	342.9	342.9
D	in	5.75	6.25	6.75	7.25	8.50	10.75	12.25	13.25	14.50	15.25	16.50	18.75
	mm	146.1	158.8	171.5	184.2	215.9	273.1	311.2	336.6	368.3	387.4	419.1	476.3

PMP Precision valve Company Ltd. Is a progressive supplier of current products. The features, materials of construction and dimensional data as detailed in this bulletin are intended for your reference only, and should not be relied upon unless confirmed in writing by PMP Precision Valve Co. Ltd.. Certified dimensional drawings are available upon order receipt.