



Limit Switch Box Explosion Proof

YT-860



- Visual Position Indicator
- Spline and Spring Loaded cams
- Multipoint Terminal Strip
- 3/4" Conduit Entries
- Captive Cover Bolts
- Easy Mounting Brackets

Specification	Standard	Option	Standard	Optional
Enclosure Protection	Weather proof, IP67 / Nema 7			
Ambient Temperature	-20C ~ 80C			
Conduit Entry	2 x 1/2"NPT	PF 1/2", PT 1/2" M20, PG13.5		
Switches	Mechanical switches x 2		SS5GL Omron 250AC 3A, 125V 5A 250DC 0.2A, 125V 0.4A, 30V 4A	SS10GL Omron 250VAC, 10.1A, 125VDC 10.1A 250VDC 0.2A, 125V 0.4A, 30V 4A
	Proximity sensor x 2		PS17-5DNU Autonics Operating 12-24VDC Allowable 12-30VDC	NJ2-V3-N (P&F) 0-25VDC Distance 2mm
Terminal	8 Points			
Shaft	Standard Shaft 17mm	Long Shaft		
External Coating	Black	Red, Blue, Yellow Green, Silver		
Weight	1.5Kg			

Material	
Housing	Aluminium die - cast
Shaft	Stainless Steel
Indicator Cover	Polycarbonate
Indicator	ABS / Polycarbonate
Cam	Polycarbonate
Spring	Stainless Steel
O - ring	NBR
Bracket	Stainless Steel

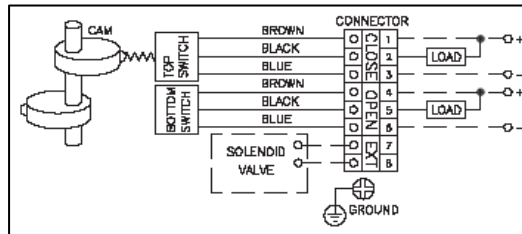

Proximity Sensor

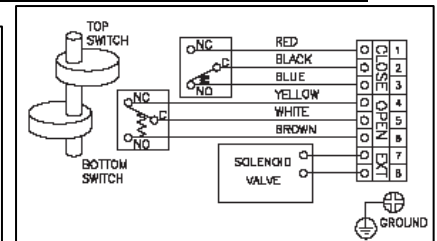

Mechanical Switches

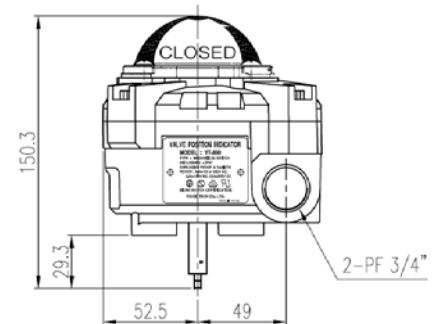
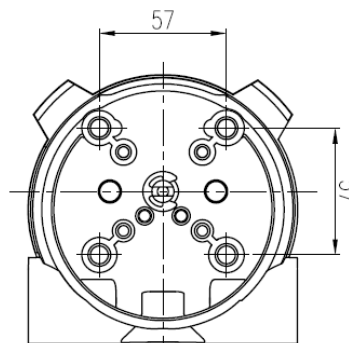
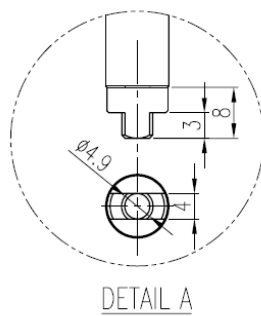
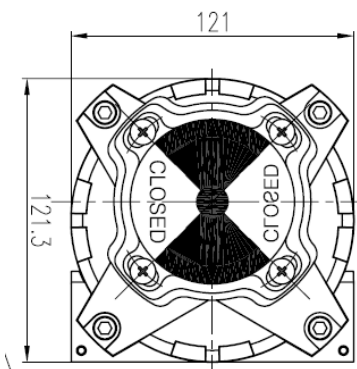

PMP Precision Valve Company Ltd. Is a progressive supplier of current products. The features, materials of construction and dimensional data as detailed in this bulletin are intended for your reference only, and should not be relied upon unless confirmed in writing by PMP Precision Valve Co. Ltd.. Certified dimensional drawings are available upon order receipt.